



# St. Benedict's High School

# NEWSLETTER

Summer 2024



Follow us on X: [@stbenedictsren](https://twitter.com/stbenedictsren)



Dear Parents/Carers,

Welcome to our Summer edition of St Benedict's News. I am delighted to be sharing a compilation of some of the many activities, successes and achievements of our young people.

Recent events have ensured a busy but exceptionally positive end of year for the school reflecting a great deal of hard work on the part of our young people and staff.

Our senior pupils have recently returned to school following the SQA exam leave. Months of hard work and extra study sessions allowed our young people to prepare well for the exams and we now look forward to hearing the positive results at the start of August.

Our new S5 and S6 pupils have already thrown themselves into the life and work of the senior school. S6 pupils have now taken on the leadership roles vacated by the departing pupils.

Various whole school events have taken place in recent weeks including our House group celebrations, sports day and the S6 Prom. These events and many others are captured in this newsletter.

I hope you find the following information helpful and, as ever, we welcome your comments.

I wish you a relaxing and enjoyable holiday, whatever you and your family have planned, and I look forward to welcoming the whole school community back to school at the start of next session – Friday 16<sup>th</sup> August.

*Alan Taylor*

Alan Taylor  
Head Teacher



**RESPECT – LOVE – TRUST – TOLERANCE – INTEGRITY**

# Let's Achieve Together







St Benedict's High School is excited to launch our new Let's Achieve Together action plan. This is an incredible opportunity for pupils to be rewarded for giving their best every day. Each pupil will gain a Merit every period, with the opportunity to gather 33 Merits, in total, across the full school week.



At the end of each term, there will be a prize draw for vouchers and each pupil who has managed to retain 95% of their Merits across the term will have a chance to win one of five sets of vouchers per year group!

This poster will be displayed in every classroom, reminding pupils of the high expectations we have for each learner so that they are able to learn and thrive in their time at St Benedict's.

For updates please login to [Satchel:One](#).

## LET'S ACHIEVE TOGETHER - ACTION PLAN

- A** Arrive to class on time and get ready to learn. 
- C** Concentrate and listen to the teacher. 
- H** Have a positive growth mindset. 
- I** Involve yourself fully in the lesson. 
- E** Ensure you stay on task. 
- V** Value and respect your teacher and classmates. 
- E** Exit the class in a calm and orderly manner. 

 Respect - Love - Trust - Tolerance - Integrity 

## Head Boy and Head Girl



**Head Boy**  
Patrick McElhinney

**Head Girl**  
Olivia McInnes

## Depute Team



**Depute Head Boys**  
Emmanuel Fatuyi  
Liam McLaughlin  
Aaron Rai



**Depute Head Girls**  
Saoirse Dunn  
Annie Cranfield  
Orlaith Locke  
Kiera McCormack  
Flora Okungbowa

# House Captains



## St. Oscar Romero House

Broghan McCredie  
Emily McKenzie-Adams  
Noah McSkimming  
Sophie Chambers



## St. Teresa of Calcutta House

Lauren Murphy  
Jeshof Jenith  
Ruby McKeeman  
Katie Cavanagh



## St. Josephine Bakhita House

Niamh Armour  
Eilidh Fitzpatrick  
Oliver Stan  
Sophie Murray



## St. Maximilian Kolbe House

Ava Garrity  
Harmony Etinosa-Iroghiendo  
Marley Biernacki  
Anthony McArthur



# School Uniform - Dressing for Excellence

**Uniform is an important part of our school identity.** It reinforces who we are as a community and allows students to feel a sense of pride in their school. It also helps prepare pupils for life after school where many will have to dress smartly for work.

Over the past four sessions, there have been **significant improvements** in our standard of uniform. An increasing number of pupils are now wearing blazers and I am delighted to report that over 99% of pupils are now wearing all black footwear. **A big thank you to you as parents/carers for supporting this.**

Our main driving force for striving towards 100% of pupils wearing black shoes is to ensure equity for all. No pupil or parent should feel pressured to wear/buy an expensive pair of “converse style” trainers. This was also highlighted by our young people through our pupil voice.

**Our improved standards of uniform coincides with our increasing pattern of attainment.**

The wearing of school uniform:

- Is invaluable in conveying a sense of community, wellbeing and purpose.
- Indicates a sense of pride in the school and helps pupils to form positive attitudes to the school and their school work.
- Protects children from the harmful effects of social distinction and competitive dressing.
- Promotes the school's identity in their community, with our immediate neighbours, local business and industry.
- Assists staff in the task of supervising pupils and keeping unwelcome visitors out of the school.

The school uniform consists of :

- A white school shirt/blouse, and school tie which is visible at all times. S4, S5 and S6 will wear the Senior tie.
- Tailored black trousers or black skirt - leggings, denims and tracksuits, are **not acceptable**.
- A school blazer with badge.
- Comfortable footwear (black in colour). **No Converse style trainers unless fully black in colour.**
- Plain black jumper or cardigan (optional). Black school jumpers should be of an unbranded style that allows the school tie to be clearly seen. **Hoodies are not allowed.**



## Attendance Matters – Is your child missing out?

The importance of good attendance and timekeeping is essential for pupils to fulfil their potential. It is also a crucial life skill. If a pupil is not in school, they are missing learning.

It is important **we work together** to monitor this closely.

Parents/carers are by far the most important influence on children's lives and learning and are vital in shaping the mind set and behaviour of children.

You will receive attendance and timekeeping updates on all tracking reports you receive. Please pay attention to this.

What these figures mean:

## Poor Attendance and Timekeeping – Missed Learning

100% Attendance	0 Days Missed	Gives your child the best chance of success and gets them off to a flying start.
95% Attendance	9 Days of Absence 1 week and 4 Days of Learning Missed	
90% Attendance	19 Days of Absence 3 Weeks and 4 Days of Learning Missed	Less chance of success. Makes it harder to progress.
85% Attendance	27 Days of Absence 5 Weeks and 3 Days of Learning Missed Almost half a term missed	Serious implications on learning and progress.
80% Attendance	36 Days of Absence 7 Weeks and 3 Days of Learning Missed Half a term missed	
75% Attendance	45 Days of Absence 9 Weeks and 1 Day of Learning Missed Almost 1 whole term missed	

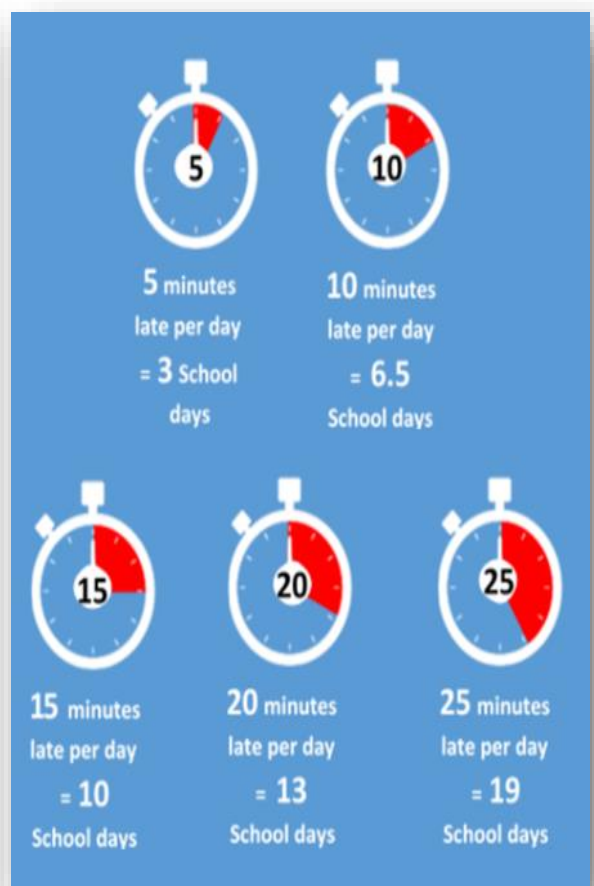

## What can you do to help?

- Be aware of the impact of regular absences – missing school is missing out.
- Take family holidays outside of term.
- Try to arrange non-urgent dental and medical appointments outside school hours.
- Establish a good routine in the mornings and evenings so your child is prepared for the school day ahead ; build up good habits of punctuality and attendance.
- Be involved with your child's education and school – ask questions.
- Inform the school if you child is absent due to illness or other reason.
- Discuss any problems or difficulties with the school, staff are there to help and will be supportive.

If your child has 90% attendance,  
they will have the equivalent of:

$\frac{1}{2}$  a day off per week

19 days off per year

247 days off their school career of 13 academic years,  
equivalent of 1 year of lost education.

We do understand that pupils can be unwell from time to time and that some pupils are affected more than others by health issues including anxiety. These pupils will be fully supported by school staff in their learning journey.





# House System

Our House System is now well established, encouraging young people to participate in and take on a variety of leadership roles.

Pupils and staff can achieve house points as detailed below.

## Tracking

### Behaviour and Effort

5 points for a GRADE 1

3 points for a GRADE 2

### Attendance

>95% per tracking period = 25 points

### Departments

Each department issues 500 points on their chosen month.

## Achievements

House Hero – 50 points

Pupil submission on paper, in SE, or parent/carer can email into school.

### Extra-curricular Activities

Attend 10 sessions for 50 points.

Pass to PCT.

### Litter Picking

10 points.

Month	Subject/Faculty
September	Maths
October	Social Subjects
November	Modern Languages
December	Art and Music
January	Computing/Business/Admin
February	Home Economics
March	Science
April	Technical
May	English
June	P.E.

Each faculty will have a month where they will run an event within their department and award points to pupils at their end of the month departmental meeting. **TURN TO THE NEXT PAGE TO SEE WHICH HOUSE WON THIS YEAR!!!**

This year's winners are **St. Maximilian Kolbe House!**



**St. Maximilian Kolbe:  
22945**

**St. Oscar Romero:  
20242**

**St. Teresa of Calcutta:  
21438**

**St. Josephine Bakhita:  
21303**



The Chaplaincy Team organised a retreat in for our school's staff community to reflect upon the theme of 'Developing as a Community of Faith and Learning'.



Staff participated in a variety of activities to explore the nature of the Catholic school, our vision, values and aims, and working together as a Christocentric community.

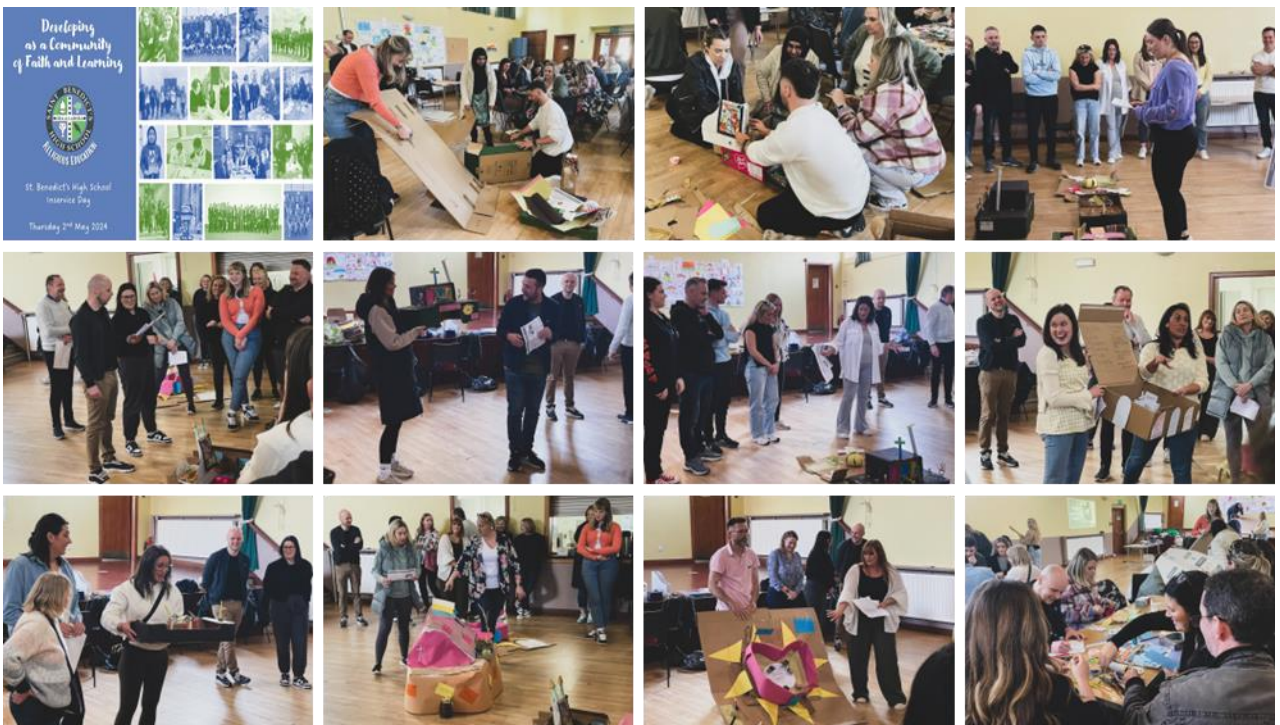

We had a great together! Thank you so much to everyone who helped to organise our successful day, and to St. Aidan's Parish in Johnstone for hosting us in their hall and having us join the parish community for Mass.



In preparation for Easter, we gathered as a school community to reflect upon the events of Jesus' passion, death and resurrection.

Thank you to everyone who made our Paschal Triduum Reflection Services possible. To our priests, Canon McMahon and Mgr. Denis Carlin, our eighteen readers, our musicians, our Liturgy Committee and everyone who joined us in prayer.

### Friday Lunchtime Mass

Mass is offered in the Oratory every Friday lunchtime at 12.25 and is very well attended by pupils and staff.

We are very grateful to our local clergy for the commitment to this extremely important part of our school week.

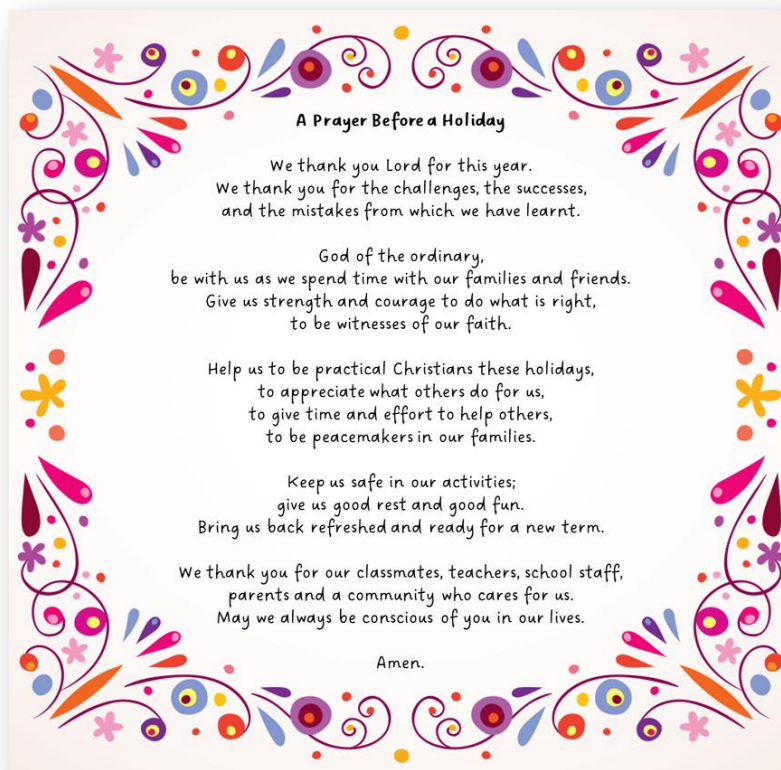



# Malawi Partnership

The partnership between St, Benedict's High School and St, Patrick's Minor Seminary was formed in 2013 with the shared intention of developing and supporting both schools to become centres of excellence as communities of faith and learning.

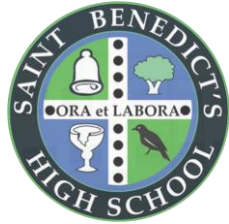

**ORA ET LABORA**  
“PRAY AND WORK”

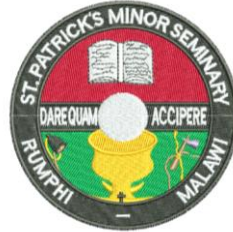

**DARE QUAM ACCIPERE**  
“BETTER TO GIVE THAN TO RECEIVE”

The mottos of our two schools encapsulate the values which lie at the heart of our partnership and which give direction and purpose to our endeavours. This is an equal partnership between our two communities and the work of our partnership features the following characteristics:

- a commitment to building mutual trust and respect to support our young people in their development;
- a commitment to learning about each of our cultures in a variety of ways through our curriculum and through exchange visits;
- a commitment to supporting each other, in a variety of ways, in achieving the central aim of this partnership, namely, to enable our young people to achieve their full potential in life and to become the people God is calling them to be.

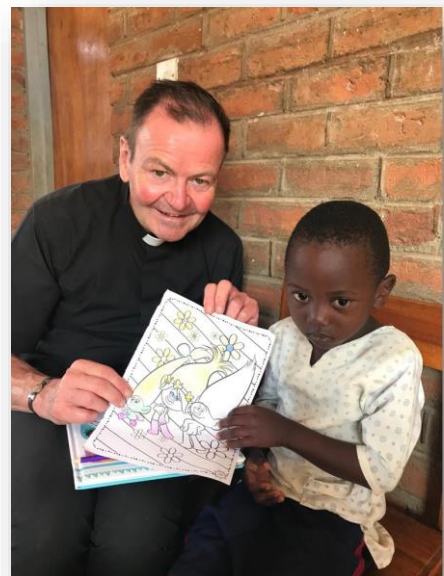

## Malawi Visit 2024

It is with great joy that we are able to return to St Patrick's this month after a five-year gap due to Covid restrictions. I am accompanied on this trip by our school Chaplain, Canon Michael McMahon and seven outstanding new S6 pupils: Grace Clark, Keira McGroarty, Jemma Johnston, Trinity McGee, Ava Wilkie, Aidan McGowan and Aaron Rai. Our pupils attend classes every morning, after 6:30am Mass, then work in the local community each afternoon.

In the grounds of St. Patrick's is St. Magdalena's boarding school for disabled primary children where we spend most afternoons. I prepare our pupils by explaining to them that the kids don't need our sympathy or tears; just our time and our friendship. Even now after all these years I still find myself fighting back the tears as children who are either missing limbs, have cerebral palsy or have been severely burned sing and dance for us. Their motto is "disability is not inability" and they demonstrate that in spades as we play games and teach them Scottish songs and dances. Their farewell song of "Goodbye, though you are far away, we will never forget you" usually leaves me with teenagers in a puddle of tears!

*Bernadette McFadden, Depute Head Teacher*

"I'm excited to experience a different culture and lifestyle from what I'm used to and I'm looking forward to meet the boys at St Patrick's and learn more about their day-to-day life."

*Aaron Rai S6*

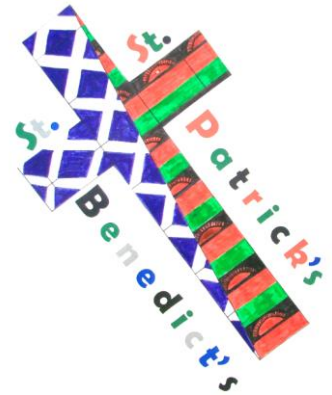

Please follow our adventures on our [blog](#).



Upon their return to Scotland, our Malawi pupils will take up senior leadership roles in our school.

We celebrated the Class of 2024 in style at the Dalmeny Park Hotel!

Many thanks to all those who worked so hard to make sure we had a fantastic night.





# News from St. Maximilian Kolbe's House

Being appointed (Acting) Head of St Maximilian Kolbe House Group is an absolute honour for me. Having worked in St Benedict's for six years, I am delighted to take on this role while Mrs Glen is on maternity leave. We all wish her and her new family all our love and best wishes at this special time.

Having the opportunity to get to know more about our pupils and their fantastic achievements is wonderful. Our pupils really are amazing!

Here are some of our pupils' achievements. As always, pupils are reminded to alert me to any achievements, in or out with school, so I can ensure to congratulate and award appropriate house points!

Pupils in St Maximilian Kolbe House are 1.2, 2.2, 3.2, 3.5, 4.2, 5.2 and 6.2.

Thanks,

Mrs Doyle



## House Captains – A Big Thank You!

Well done to our Junior and Senior House Captains for volunteering themselves for such an important role within the school this session. Representing our house group as House Captain is a fantastic leadership opportunity and we thank you all for your contribution you have gave this year!



**Senior House Captains: S6 – 6.2**

**Niamh Tonge and Nikki Lavery**



**Junior House Captains: S3 – 3.2 and 3.5**

**Chiedu Nwokaebia, Marium Mosuro, Catherine Morier and Ebony Brogan**



## Attendance Matters 100%

Well done to the following pupils with 100% attendance so far this year:

- S1 India Rai
- S2 Toby White
- S3 Mariam Mosuro
- S4 Ryan McKay, Lynn Muteveri
- S5 Mirren Carter, Aaron Rai, Annalise Muggins,  
Keira MacCall and Flora Okungbowa

Attendance matters!



Every day counts!



### Outstanding Tracking: 1s across the whole year!

- S2 Ella Whitehorn
- S3 Abbie Anderson, Matthew Broadhurst, Ebony Brogan,  
Owen Campbell, Harry Cavanagh, Sean Doherty, Curtis Hope  
and Jessica Neeson.

"Do not forget that holiness consists not in extraordinary actions, but in performing your duties towards God, yourself, and others well."

*St. Maximilian Kolbe*

## Wider Achievements

Detailed below are some of the successes of members of St. Maximilian Koble's House. Please remember to inform me of any achievements out with school so they can be celebrated!

Well done everyone from St Maximillian Kolbe House in all your positive contributions to our school and wider community!



# ST. MAXIMILIAN KOLBE'S HOUSE WIDER ACHIEVEMENTS

**Hayden McKay** plays in Renfrewshire's Concert Band and performed at Paisley Town Hall in the spring concert. He was also awarded the Endeavour Trophy at his recent Boys Brigade awards night, along with his Company Section Silver Award for eight years at Boys Brigade.

**Harry McKay** is also part of Renfrewshire's Concert Band and performed at Paisley Town Hall in the spring concert. Harry is achieving awards with Boy Brigade and is volunteering with the Anchor Boys, and at other events.

**Max Macdonald** was awarded Male Student of the Year by his Muay Thai Gym, OB's. Max has been selected for the Scottish Muay Thai Squad and recently achieved a silver medal at the WKA World Championships!

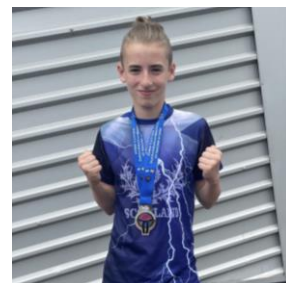

**Rebecca Reid** is a keen footballer and helps coach with training Under 8s Thorn Athletic Girls.



**Madison Reyes** passed her 2nd Mon in Judo.

**Jack McLaughlin** has received his Saltire Award for 50 hours volunteering with St Mirren FC.



**Hayden Sloan** has achieved his Saltire Award by completing 50 hours of volunteering as a match day ball attendant with Street Stuff at St Mirren Football Club.

**Emily Ogilvie** is doing very well with her horse riding and is now gaining work experience with the stables.

**Mariam Mosuro** is doing well with her netball and is also volunteering to help at the 110th Year of Girls Brigade Service.

**Jessica Neeson** completes in a variety of dancing and regularly comes 1st or 2nd. Her Hip Hop team have become Scottish Champions!

**Sonny Ferguson** was the star of the show in the annual production with Johnstone Phoenix Youth Theatre in Matilda and standing ovations at every performance. It was fabulous!

**Catherine Morier** volunteers at Johnstone Burgh Football Club in the cafe/tuck shop. She is now interviewing Johnstone Burgh's manager on end of game interviews every game home and away. Fantastic livestreams are available on

[YouTube](#).



Well done to all in St. Teresa's House for your outstanding efforts this year. We successfully celebrated our House Assembly before Christmas where pupils received awards and certificates for their many achievements throughout this school year so far. Our House enjoyed spending time with other year groups taking part in quizzes, games and prize giving!



A big thank you to this year's **House Captains** for St. Teresa's House!

**Senior Captains:**

Patrick McNish and Sandy Bamba – Good luck moving on to university!

**Junior Captains:**

Lucas Leckie and Katie Moynihan

Well done to the pupils below who have achieved **100% Attendance Certificates** this year:

- 1.3 Gabriel Lesiak, Lewis Crawford, Keziah Massengo Fleury and Jakub Swistak.
- 1.5 Danny Moynihan, Chukwuka Nwokeabia, Chloe Martin, Meghan Simpson, Joseph Smith and Nathan Quinn.
- 2.3 Wojciech Dudek, Ruby McKeeman, Rhona Bos and Jeshof Jenith.
- 3.3 Caelan Bonner and Liam McGall.
- 4.3 Ryan Gallagher and Thanatip Meesat.
- 5.3 Sophie Murray.
- 6.1 Shekina Massengo Fleury and Aaron Wilson.



# ST. TERESA'S HOUSE WIDER ACHIEVEMENTS



Congratulations to **Dylan Mann (4.3)** who achieved a 19m distance with the discus. Even more impressive that he did this with his eyes shut due to hay fever! He also achieved 2nd place in javelin and shotput.

**Ava Hampson (2.5)** is a competitive Highland dancer, recently taking part in the British association of teachers of dance scholarships where she placed 6th out of 24!

**Ruby McKeeman (3.3)** and her Junior Cheer Team took first place at the Soar Reign Supreme Competition and additionally received an invite to compete at The Allstar Worlds in Florida in 2025! Ruby has also had confirmation that she has successfully achieved the Chief Scouts Gold Award, the highest award a scout can achieve! Ruby has completed nine challenge awards plus six activity awards over the last three years to achieve this incredible award.



**Callum Brady (4.3)** spent a week at a Fire Station learning the role of fire fighters, kit management and team working at a Road Traffic Accident. He also successfully completed a First Aid course during this week. In addition, he completed a three-day residential course at Stirling University in partnership with Thales Engineering and achieved his 'Introduction to Engineering' certificate.

**Yana Kushta (5.3)** has been volunteering in Barnardo's charity organization, helping to organise family and kid's activities for refugees. She helps many children and their parents to feel included and can help distract a little bit from difficulties of being in other country.

**Katie Moynihan (4.3)** competed at the CRN Irish Open Championships with her Irish Dancing School at the end of April. She has worked so hard, showing amazing resilience, commitment and endurance to get this high level that she performs at. In her Team dances she achieved two 1st place medals, two 3rd place medals and an amazing result of 2nd place in a fiercely competitive round. In her solo award, she won 3rd place in the under 15 Meanghrad category. Next stop is the World Championships in June!



Well done to all our winners, don't forget to update us on any other achievements throughout the year for our house points!

WIDER ACHIEVEMENT



*I hope you and your families have a lovely summer!*



*Mrs Knapton  
Head of St Teresa House*

*"It's not how much we give  
but how much love we put into giving."*

*St. Teresa of Kolkata*



# News from St. Josephine Bakhita's House

As my first year as head of St. Josephine Bakhita House is coming to a close, I would like to thank all staff, pupils and parents for making St Benedict's such a great school. It's a joy and privilege to be back after two years working overseas.

I hope you all have a lovely summer break.



## Junior House Captains

Aimee and Ben are exemplary pupils who have been great role models for everyone in Bakhita House. Thank you!

Here they are handing the role onto Oliver Stan and Eilidh Fitzpatrick.



Students who had **1s** in every tracking report in Session 2023-2024:

- Eason Gao 1.4
- Erin Hampsey 1.4
- Cara McIntyre 2.4
- Ben Surpless 2.4
- Hajarat Aroworowon 2.5
- Julia Armatys 3.4



Well done to the students below who have over **95%** attendance:

- 1.4** Tommy Bowman, Eason Gao, Charlotte Gorrie, Matthew Houston, Thomas McCormack, Olivia McIntyre, Aidan McWilliams, Faith Odudu and Ferdinand Tabot.
- 2.4** Monica Adams, Jason Devoy, Robyn McIntyre Fletcher, Cara McIntyre, Ben Surpless, William Parker and Aadhesh Satheesh.
- 2.5** Ire Aboyeji , Hajarat Aroworowan, Grace Caldwell, Ambila Cookey, Eilidh Fitzpatrick and Alyssa Murphy.
- 3.4** Grace Agbontaen, Julia Armatys, Anthony Burns, Lily Connolly, Aimee Duggal, Zoe Keenan, Blair MacDonald, Keelan McDonald, Chad Inegbonese and Cher Duru Inegbonese.



## ST. BAKHITA'S HOUSE WIDER ACHIEVEMENTS

**Ferdinand Tabot**  
Football

**Stephen Hunter**  
Kiltwalk, raising £755 for charity!

**Gemma Carruthers**  
Young carer

**Ben Sheridan**  
Drama

**William Parker**  
Archery

"Seeing the sun, the moon and the stars,  
I said to myself, 'Who could be the Master of these  
beautiful things?' I felt a great desire to see him,  
to know him and to pay him homage"

*St. Josephine Bakhita*



# News from St. Oscar Romero's House

Well done to House Romero on another wonderful year. Our house continues to build on our values, and this was highlighted by our Junior House captains Sophie Coutts and Lucy McElhinney who said, 'It is a pleasure to be part of House Romero and everyone from each year group helps one another'.

The following pupils have made outstanding contribution to their House group this session and get the 2024 House Ethos award: Sean Colligan and Zach Adams. Well done!



Well done to Jessica Walters in 2.1 who has a perfect 100% attendance record this year.



Well done to Andaru Jingga and Zara Muir who won pupil of merit awards for their outstanding tracking across all subjects.

## ST. ROMERO'S HOUSE WIDER ACHIEVEMENTS

The following pupils have been awarded points and certificates for achievements out with school, well done!

**Noah McSkimming:**

Pace Performance 'Chitty Bang Bang'

**Sean Dempsey:**

Under 15 District Football Selection

**Kiera Hutchison:** Scottish Highland Dancing

**Liam McLaughlin:** Under 18 District Football Selection



Despite it being the busier side of our secondary calendar, we managed to squeeze as many opportunities as possible in for our young people to broaden their horizons and deepen their knowledge of the world of work.

We kicked off 2024 by teaming up with W. H. Malcolm and visiting their Heritage Centre at the start of January, with every single student in S3 gaining the insight in to all the different job types that can be under the same roof. Our S3s also had the unique experience of undergoing a mock interview process with the employees from W. H. Malcolm. S3s felt a little nervous at first, but by the end of the two days, we couldn't get them to stop talking about how much they enjoyed their interview experience.



Our S4 students received 1-1 feedback on interviews and their certificates of achievement from DWF Law Firm and 4 of our young people were selected to return for real life work experience during the summer months. Well done to everyone and good luck to the four recruits for work experience: Sean Colligan, Zachary Adams, Krista McSwegan and Andrew Miller.



Our S3s were afforded the opportunity by Renfrewshire Council to attend UWS and WCS on a two-day visit to the faculty of Creative Industries in both campuses. This enabled the students to put their transferable skills into practice and find out more about what each faculty has to offer.



Our Dragon's Den team composed of Ebony Brogan (S3), Alan Matlacki (S4), Zachary Adams (S4), Sophie Murray (S5), Ava Garrity (S5) and Kiera McCormack (S5) They delivered an outstanding pitch to the 'Dragons' at St Mirren's Football Club and were invited to W. H. Malcolm HQ to showcase their product.



Our Digital Literacy Café with ROAR charity was in full bloom from January – April with our students from S4- S6 working with older adults in the community. This was a huge success and something we want to do more of in the years to come. It was something the students at the S6 Prom mentioned about the highlights of their year as they didn't realise just how fruitful an experience it would be, and that they missed having regular updates and fun stories from the older adults in the community.



Our Staff and Students took part in Beginner's guide to being "Barista Ready". We had a lot of fun and learned most standard coffees. We will be taking on part two for Barista Latte Art in late August/September.

Our S2s visited the brand-new Virgin Money building in Glasgow, and they had the opportunity to develop their employability skills to become more work ready. Alongside Govan High School, we were invited to this Collaboration Event by our partners DWF Law Firm. They explored the themes of health and wellbeing and the impact of social media during Health Week in Scotland.



Last, but certainly not least, six of our senior pupils were invited to a very special event held by the Chamber of Commerce and Scottish Leather Group at the Lynnhurst Hotel. We listened to the CEO of Scottish Leather telling us about how they are where they are today, and it gave the students an opportunity to network with lots of people from prestigious companies about their apprenticeship programmes. We've managed to hook up with Scottish Leather in Bridge of Weir for a site tour, Arnold Clark for some education on how to apply for apprenticeships and Altrad, are even sending four young ladies to their open day next week for a "Women into Engineering" event.



## UPCOMING

We are involved in a trail blazing event and are one of two schools in Scotland involved in a national launch event taking place at Malcolm's Heritage Centre with employers from all over the UK. This will take place just before we finish up at Summer and I'm afraid we'll go to print before we manage to upload pictures – so keep your eyes peeled for it in the Twitter page [@StBensCareers](https://twitter.com/StBensCareers) and our next newsletter.

A special mention to our associated primaries, W.H. Malcolm, Linwood Community Childcare, Chris Allan Accountancy, Active Communities, Mast Architects, EasyJet, My Future Pathways, ROAR, DWF, Virgin Money, Aggreko, CITB Scotland, DYW WEST for all the opportunities for our young people.

I arrived at St Benedict's High School last summer and immediately felt a sense of belonging.

It has been a pleasure to get to know all the talented, young people who attend our school and see them flourish both academically and socially.

Having had a former career in Technology for Finance, a highlight for me has been running our S1 STEM Club where it has been a joy to experience our pupils' curiosity and creativity in action. To see our S3 pupils lead the way by organising some excellent challenges, sharing their own passion for STEM, developing leadership skills and inspiring our younger pupils.

The work ethic of our pupils is impressive across all year groups however I have been especially impressed in the run up to the SQA exams by the number of pupils who attended supported study and continue to come together to support each other, in school, during exam leave.

I am very excited to be returning next year on a permanent basis and continuing to be part of such a vibrant and supportive school community.

*Mrs Biggins*





# My First Year as Depute Head

My first year as Depute in Saint Benedict's has been an absolute joy. The values of the school truly do permeate every corner of the building.

From Day One, I was welcomed by staff, parents, and pupils alike. In my first week, I was even presented with HFT's finest rock buns from a glorious group of S3 girls (they were lovely, by the way!). And from that moment on, I felt the calm, yet purposeful ethos of the school everywhere I went.

Having responsibility for the new S1 and S4 pupils has been nothing short of a privilege. The new S1 pupils very quickly embodied the school values and enhanced the already pre-existing strong sense of community. And my S4 pupils, who were embarking upon one of the most important academic years of their lives, conducted themselves with diligence and maturity – I'm so proud of them! I look forward to seeing both year groups blossom over the next few years.

So, what will next year bring for my pupils and I? Well, my intention is to support them to use their God-given gifts and talents wisely so that they continue to thrive and grow as diligent, yet curious young people who honour the school motto of hard work and prayer.

I cannot thank the staff enough for making my first year here so enjoyable; their kindness and patience has allowed me to instantly feel part of Saint Benedict's school community.

Thank you,

Anna Caira



# Support for Learning

## Outdoor Learning Group

Well done to our Outdoor Learning Group who successfully completed their John Muir Discovery Award! Pupils took part in a range of activities with fire lighting and bird box making being the firm favourites!



## English as an Additional Language

Miss McGinlay, EAL teacher, has been an invaluable support to number of our pupils this year, particularly those who have recently joined the school!

## Digital Literacy Group

S1's had a fantastic course with Mrs Boyd, upskilling themselves and building confidence with their digital literacy!

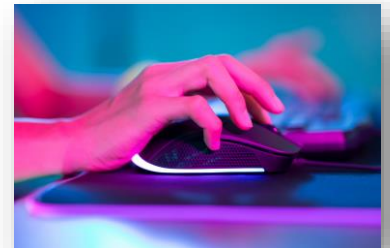

## Congratulations!

Well done to Ciaran M who completed his N4 Sport and Recreation!

## Moving On

James W leaves us after another great year! James has worked incredibly hard this year on his studies as well as helping Mr Love in the Library! Good luck James, keep in touch!

# GOODBYE!



## P7 Transition

We have been out to visit our soon-to-be S1s, taking part in Health and Wellbeing sessions. We can't wait to welcome you all!

Over the past few years, we have continued to develop our digital learning approaches. Our main platforms continue to be Satchel One and Microsoft teams.

Satchel:One continues to be the platform we use to provide homework for pupils. This platform also allows yourself the opportunity of keeping up-to date with your child's homework and submission dates, using the unique Parent Code each child is supplied with.



If a pupil forgets their password for the website, all teachers can reset their password. However, please direct pupils to see **Miss Reid (Business Studies)** if you would like to receive your child's Parent Code or any other help regarding Satchel:One.



You can also visit the school website: <https://www.oraetlabora.co.uk/> for videos and support on Satchel:One.

Microsoft TEAMS may be used as a pupil learning platform - resources linked to their daily lessons and courses are made available for them to access. Our website has further information and instructions.



## Homework

Homework and home study continues to be a crucial part of learning.

As a guide your child should be working for approximately these times per week:

- S1-S3: 5 hours
- S4: 6 hours
- S5/6: 7 hours

Throughout the year there is a supported study programme for senior pupils, and we have recently introduced a weekly lunchtime Homework Club for S1- S3 pupils. Please encourage your child to attend.

Skills Development Scotland is Scotland's careers service, and their Careers Advisers are available to support you and your child throughout their time at school. Our SDS Careers Adviser is Audrey McNab you can get in touch through the school or by email [audrey.mcnab@sds.co.uk](mailto:audrey.mcnab@sds.co.uk)

The Careers Adviser supports pupils at key times such as starting S1, making subject choices, and preparing for moving on from school. From the beginning of term, the Careers Adviser has been working with senior pupils helping them to develop their career management skills and supporting them with their career planning, through 1:1 meetings and group sessions.

### Skills Development Scotland (SDS) Results Helpline: 0808 100 8000

The SDS Results Helpline offers support to SQA candidates receiving their NQ results (for Nationals, Highers, and Advanced Highers). You can talk to SDS's expert careers advisers about course vacancies at colleges and universities, Confirmation and Clearing, and get advice about Foundation, Modern, and Graduate Apprenticeships, jobs, volunteering, or staying on at school.

The Results Helpline is open:	Tuesday 6th August	08:00 - 20:00
	Wednesday 7th August	08:00 - 20:00
	Thursday 8th August	09:00 - 17:00
	Friday 9th August	09:00 - 17:00

There's also lots of results support on Scotland's career website, My World of Work. It's packed with advice, information, and resources. [www.myworldofwork.co.uk](http://www.myworldofwork.co.uk)

If you would prefer to speak to someone in person, you can visit an SDS centre or community venue to talk to a careers adviser about your results and next steps. No appointment is necessary. Find out what's close to you at [www.skillsdevelopmentscotland.co.uk/contact-us](http://www.skillsdevelopmentscotland.co.uk/contact-us)

BSL users BSL users can use Contact Scotland BSL for support to speak to an adviser. You can use their app to sign with an interpreter who will make the phone call for you. Visit [contactscotland-bsl.org](http://contactscotland-bsl.org)



### Useful websites:

[www.myworldofwork.co.uk](http://www.myworldofwork.co.uk): Scotland's careers website.

[www.apprenticeship.scot](http://www.apprenticeship.scot): Your one-stop shop for apprenticeships.

[www.digitalworld.net](http://www.digitalworld.net) : Digital World promotes the skills and training needed to work in Scotland's tech sector.



# Parents in Partnership

Following on from our successful Cani Coaching programme delivered at Christmas we have been meeting with parents regularly to deliver training tailored to meet the needs and wants of parents. With the pressure of exams, social media and peer relationships this year's focus has been on Health & Wellbeing.

Gordon Boyd, Senior Family Wellbeing Worker, has been working very closely with our parents and has delivered training on:

- Teenage Brain
- How to Manage Anxiety
- An Introduction to Self-harm

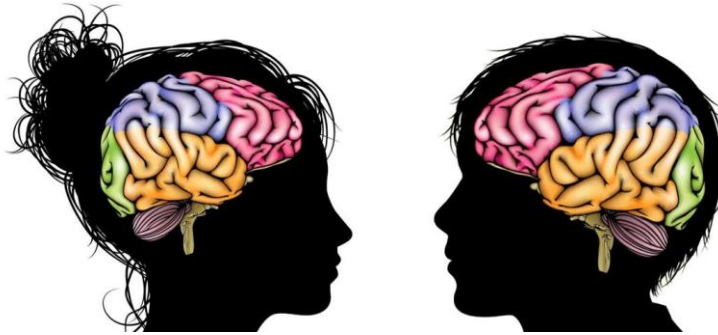

Our informal get-togethers allow parents to receive additional information on key topics while also being able to take part in group discussions and interact with other parents.

Many parents have described the sessions as being “very informative”, “relaxed and educational” and “feel the school really support parents.”

If you are interested in joining the group or would like a specific topic to be included in our upcoming sessions, please contact the school or directly get in touch with Mrs Macdonald: [gw21macdonaldgabriel@glow.sch.uk](mailto:gw21macdonaldgabriel@glow.sch.uk)

## YPI

The Youth and Philanthropy Initiative (YPI) is a powerful active citizenship programme, empowering young people to make a difference in their communities while developing a range of skills.

YPI is the biggest independent initiative being delivered in Scottish education. To date, 280 schools across Scotland have been involved, £6.8M has been granted to charities across Scotland and a total of 310,00 pupils have been involved in YPI. Each school is responsible for directing a grant of £3,000 to a local charity championed by its students through a unique programme of teamwork, research, and competition.

The whole of our S3 year group have been engaged in YPI this year through RE and SE lessons. The programme raises awareness of social issues and local charities. Pupils worked in teams to choose a social issue within the local community and then research and identify a local charity that is working to support their social issue. Each team was tasked with researching and then reaching out to their chosen charities, interviewing them, and then creating a pitch to present to a panel of judges to explain why their chosen charity should win the £3,000 grant.



Five teams made it through the semi-finals round to the grand “Showcase” event which was held on 1st February. Each team had to pitch their final presentations to our panel of judges and in front of the whole year group. The judging panel found it very difficult to decide between the five groups as they all presented their pitches to such a high standard. In the end, our winning team have secured a £3000 grant to a local charity Jubilee House, a Scottish charity based in Paisley that helps women and children escape domestic abuse. Our young people showed tremendous courage in raising such a sensitive issue with maturity, compassion and respect.

We can't wait to launch next session's YPI programme with the new S3 year group.

## SCQF School Ambassador Programme

The SCQF School Ambassador programme offers schools the opportunity to learn more about the benefits of the SCQF and the wider ways in which it supports learners such as recognising wider achievement, developing Senior Phase learning pathways in line with the Developing the Young Workforce strategy and giving equality between vocational and academic qualifications.



Our Raising Attainment team have been working busily behind the scenes to try and gain the “bronze” recognition award. On our S6 induction day we will be asking for pupil volunteers to be trained as Pupil Ambassadors. Their role will be to deliver annual sessions on the SCQF to Senior Phase and BGE year groups. They will be involved in making videos, blogs, podcasts, posting photos and posts on social media to get the message out. This is an exciting opportunity for S6 pupils to get involved with to help educate younger year groups on the new learning pathways available at St Benedict’s High School.

### Wider Achievement Opportunities

One of our many wider achievement qualifications is the opportunity for all of the new S6 to participate in First Aid training. They will be working in partnership with recognised workplace trainers to complete the “Emergency First Aid at Work” qualification.



This award not only equips our young people with lifesaving skills, but it also enhances their CVs and makes them more attractive to prospective employers. It is always a fun and informative experience which provides them with opportunities to show their abilities to learn in a new and different context from the traditional curriculum.

The First Aid Qualification is part of the Scottish Credit and Qualification Framework.

## Supported Study and Easter School

Supported Study classes have been offered throughout this session in a range of subjects in order to compliment the ongoing excellent learning and teaching which goes on in the classroom.

In January, a programme of tutorial classes across many subjects was offered at the end of each school day, as well as Saturday School for Spanish and Maths. Students benefitted from this additional support and welcomed the opportunity to deepen their learning by working in smaller class settings with subject specialists. In Spanish, students were able to spend more time on their preparation for the Speaking aspect of their assessment. Attendance at all these extra classes was very good and students provided positive feedback on the impact of this support.



*Pupils at the Spanish Saturday School enjoying a continental breakfast whilst studying!*

As we move into next session, we will be encouraging senior students to continue to take advantage of all opportunities on offer to help them to maximise their full potential.

In April our senior students on the cusp of SQA examinations were invited to attend classes during Easter School where they were able to attend a wide range of subjects across four days as well as taking advantage of a quiet, industrious learning environment which supported their study plans during the holiday.

During the exam diet, students have also benefitted from Immersion Days prior to the exam in a variety of subjects. These were delivered to allow students the opportunity to work with subject specialists immediately before their exam. This support provides pupils with last minute revision, well-being checks and reassurance on the eve of assessment.

Our students have worked extremely hard throughout this session, and I am sure that their efforts and taking advantage of the extra supports offered, will benefit them in their attainment in their exams.

## S1 STEMazing Workshop

While participating in the STEMazing workshop, all S1 pupils learned about energy generation in Scotland and the need for us to use more renewable sources of energy. Each pupil constructed a model wind turbine to better understand the technologies commonly used.



## S2 Army Workshop

The British Army visited the school to deliver a variety of STEM workshops to all S2 pupils. Challenges included pupils programming a robot to deliver aid and determining the location and identity of a hacker.

## S3 Escape Room

All of S3 were challenged to complete a STEM escape room which focused on developing their problem-solving skills. Pupils had to solve a series of puzzles to determine the names of some famous Scottish scientists and engineers.



## Young STEM Leader Programme

This term, our S3 pupils have had the opportunity to register for the Young STEM Leader Programme (YSLP) which aims to inspire more young people to develop an interest in STEM and pursue the study of STEM subjects and relevant future pathways.



As part of this programme, they have been:

- Learning about current and future opportunities in STEM that are available to young people locally, nationally, and internationally.
- Exploring their own potential in STEM.
- Developing their leadership skills by organising some fantastic activities for our S1 STEM Club



This year, the STEM (Science, Technology, Engineering, and Maths) Club at St. Benedict's High School has been a hub of hands-on learning and collaboration.

Under the guidance of Ms. Mohsan and Mrs Biggins, students have participated in a series of engaging activities that have fostered their creativity, problem-solving abilities, and teamwork skills.

Our S3s organised a fantastic STEM club for our S1s.

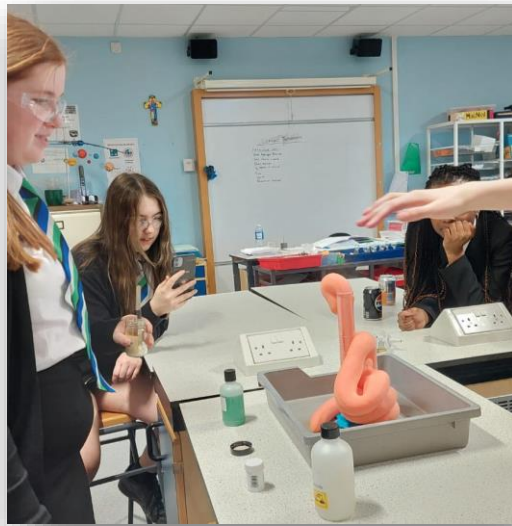

Lots of fun was had exploring exothermic chemical reactions by making elephant toothpaste.



Our STEM clubbers conducting an experiment to explore the spread of viruses - biomedical scientists in the making!



Our STEM club enjoying a density experiment with sugar, water and food dye.

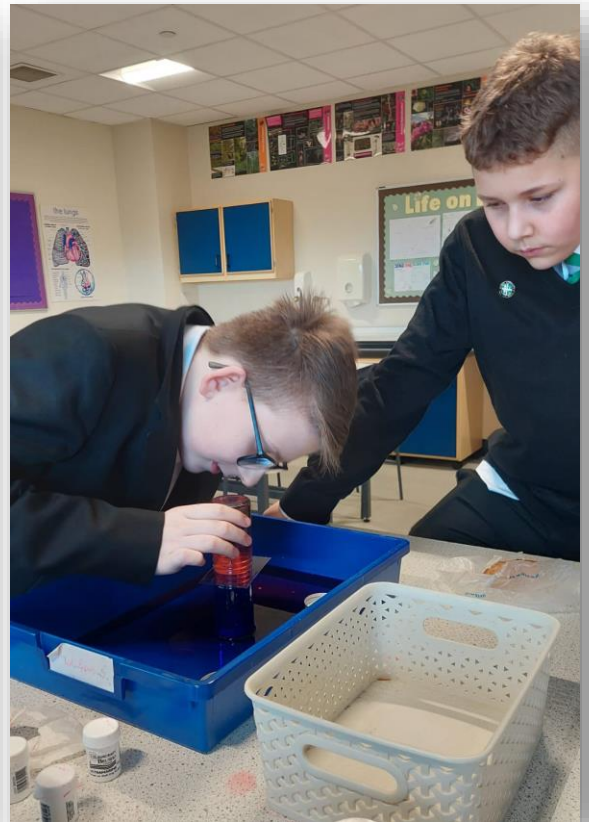

STEM clubbers acing a balancing water challenge, whilst investigating density and temperature.



# Musical Theatre Club

Congratulations to The Musical Theatre Club who worked very hard to deliver an outstanding performance of High School Musical Jr! Pupils worked exceptionally hard in rehearsals to learn their script, songs and choreography, delighting us with two superb nights of entertainment!

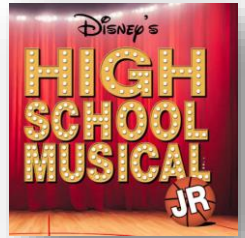

## Sky Up Academy Studios

A group of S1 pupils embarked on our annual trip to Sky Academy Studios in Livingston, where they got the opportunity to experience a day in the life of a producer, director, actor, presenter, reporter, scriptwriter, editor, and camera operator! They wrote, filmed, edited, and produced a news report on social media influencers and the final result was amazing to watch! Fantastic work everyone!



## Primary 6 and 7 Transition Programme

Cluster Primary 6 and 7 pupils took part in our Moon Landing Challenge where they were tasked with creating a short story about Outer Space. All pupils did a fantastic job at brainstorming ideas for describing plot, characters and setting as a team and individually created very entertaining stories as a result. Well done!



## IDL Software

We are continuing use of IDL, a digital programme proven to improve reading and spelling ages, with the aim to improve reading and spelling skills. Learners are enjoying using IDL and can see how it is improving their confidence in reading and writing across the curriculum. From tracking learner progress, it is clear there has already been a significant improvement in the reading and spelling ages of many pupils. In the new session, we will continue to use IDL to support learners in literacy improvement across S1, 2 and 3.

IDL can be accessed from home – if you'd like more information about how to use the software at home, please contact the school office or visit [www.idlsgroup.com/literacy](http://www.idlsgroup.com/literacy).



# Literacy at Home

## Talk

Research shows that children who speak to their parents about films, books, music, television shows, and current affairs develop effective skills to summarise the information they have acquired through reading, develop informed opinions, and develop critical thinking skills. Conversations that support effective learning don't have to be about learning!



## Read

Building and maintaining the habit of reading is as important at secondary school as it is in primary school. One of the most effective things you can do to support your child's reading is to show them how much you value it yourself. The best way to do this is to make sure they see you reading and by taking an interest in what they are reading by asking them specific questions about the book.



## Word Play

Encourage your child to become curious about language by playing with words. Can you figure out the play on words in the image below? Tweet your answers and don't forget to tag [@StBensLiteracy](https://twitter.com/StBensLiteracy)!



BGE classes have been working really hard this year and have produced some excellent work. S1 learned about the visual elements, created lovely repeating patterns and sgraffito butterflies. S2 have been working on landscape paintings, lampshade design based on reptile eyes and monoprint portraits. S3 created a mixed media sketchbook, printmaking and illustration for a book cover. Here are some examples of work from S1-S3.

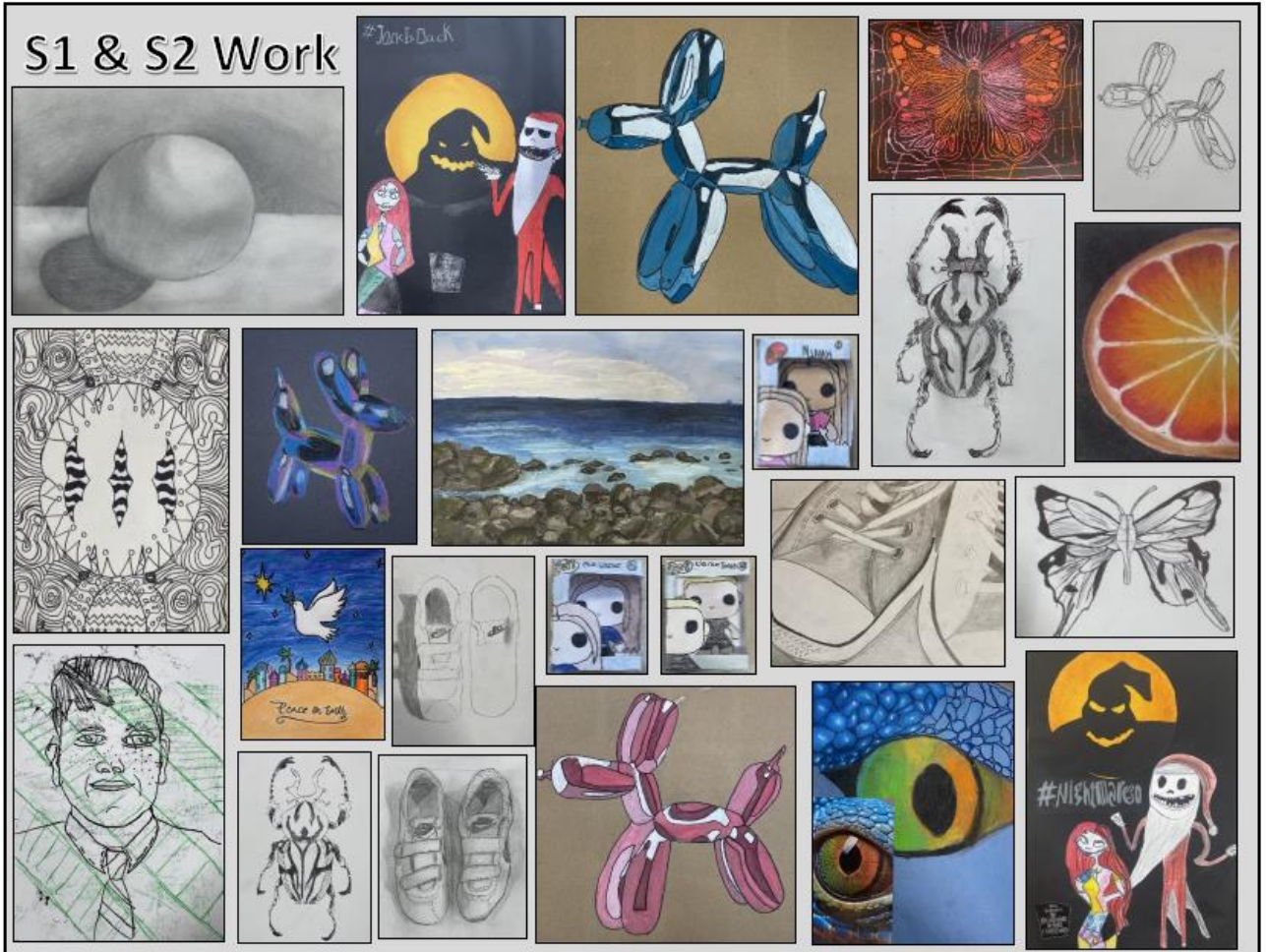

S1 & S2 Art Club will continue next year. We would love to see some new members so keep your eyes open for a start date in August.



# SQA Folios

After lots of hard work pupils finally finished their SQA folios. Pupils all worked so hard and as a result there is some beautiful work. Well done everyone. We are looking forward to some fantastic results in August.



If you haven't already, you can follow the Art Department on X [@StBenedictsArt](https://twitter.com/StBenedictsArt), this is where we can share some of the amazing work by our talented pupils.

**Keep an eye out for our end of year BGE Gallery and SQA Gallery on X .**



# Health and Food Technology

Our BGE pupils have been working hard in the HFT Department this term, developing their cookery skills and strengthening their understanding of food and nutrition.



S2 pupils have been competing in our Master Chef topic, where they learn how to apply specialist garnishing techniques and serve their food to a high standard. Each year pupils and staff vote to select the best presented plate of food.

Our 2024 finalists are:



**Ire Aboyeji**  
*Spring Rolls*



**Rhona Bos**  
*Chickpea Curry*



**Lilian MacLeod**  
*Sticky Toffee Pudding*

Senior pupils have also had a busy term in the HFT department. National 5 Practical Cookery students completed their SQA Assignment tasks; preparing a three-course meal for four people.

Starter: Vegetable Fritters with Savoury Couscous

Main: Beef Moussaka

Dessert: Pear and Ginger Crumble Tart



National 4 Practical Cookery students also completed their SQA assessments; preparing a two-course meal for four people.

Main: Spaghetti Bolognese

Dessert: White Chocolate and Strawberry Cream Roulade



National 5 and Higher Health and Food Technology students completed their SQA assignment task by developing a new food product. This year saw the return of product testing, where candidates conducted a sensory test of their prototype food product to gain feedback from their target market.



Barista Skills students had a successful year developing their practical skills using our new St Benedict's Barista Bar. They learned how to make wide range of hot and cold drinks by running our café, serving drinks to pupils, staff and visitors.





Finally, some of our very talented S3 pupils took part in the Rotary Club Young Chef Competition. They passionately dedicated their time to create a healthy two-course meal for two people.

They created recipes, organised time plans, carried out costing exercises and designed the service details for their menu.

Our two finalists travelled to Gryffe High School to compete against pupils from across the authority.



**Cael Dolan**



**Catherine Morier**

As runner-up in the local heats, Catherine Morier progressed to the regional stage of the competition. She travelled to Ayr College to compete against young chefs from all over the west of Scotland.



## Janet Coats Memorial Prize

We were delighted to celebrate the achievements of Heather Brander, S6, and Mariya Javed, S3, for being shortlisted for the Janet Coats Memorial Prize. Both students read their poems at the annual prize-giving ceremony held at Paisley Town Hall on Friday 26th April.



At the end of the session, we were even more delighted when Mariya was presented with the overall prize for this year's competition. A huge congratulations and well done!

## Vancouver Trip

You may be aware that the faculty has been involved in organising a trip to Vancouver in Canada for June 2025. We are very excited to announce that the travel company have let us know that they can offer us some additional spaces on the trip and so the opportunity to accompany us will soon be offered out to those pupils currently in S2 (and moving into S3 in June 2024).



All finer details of the trip will be issued shortly to all S2 shortly but, in the meantime, if there are any pupils who don't want to miss out on this fantastic opportunity, please come and speak to Mr. McKee or Miss Lauder as soon as you can to try to guarantee your place. We will operate on a first come, first served basis and move to a reserve list after all spaces have been filled.



## Community Fundraising for Vancouver Trip

A huge thank-you to all members of our local community who gave so generously to our young fundraisers at Morrisons in Johnstone on Sunday 28th April. A thank-you, too, to the pupils and their parents who were so willing to support us in manning our fundraising. The young people of our school got very many compliments for their helpfulness and kindness, and we appreciate not only their willingness to serve their community, but also the community's generosity in helping them to raise money.



## SQA Recognition For Departmental Courses



The English department welcomed a visitor from the SQA on Friday 3<sup>rd</sup> May to look at our Level 6 Communication and Literature course which has been running for four years now. The feedback was exceptionally positive and the SQA were delighted with the course and the opportunities it continues to provide for all of our young people. A huge congratulations to Miss Lauder and Mrs. Tennant for, firstly, designing the course and for then presenting it with such confidence and conviction during the day.

## Paisley Book Festival Author Visits

S2 and S3 students were delighted to be involved in a visit from published author Margaret McDonald as part of our school's celebration of the Paisley Book Festival. Pupils took part in a character creation workshop, followed by a Question and Answer session designed to help them hone their skills in creative writing. An enjoyable Friday afternoon was had by all! A huge thank-you to Mr. Love and Mr. Kerr, our school librarians, for organising.



Finally, we are excited to announce that our faculty has expanded in recent months. Mrs Fletcher safely welcomed a baby girl into the world at the end of March 2024. Furthermore, by the time this newsletter is issued, Ms. McAllister of the Modern Languages department will have left us to welcome her baby boy into the world. We wish them every happiness and look forward to them visiting us with the newest members of our extended St. Benedict's family soon.

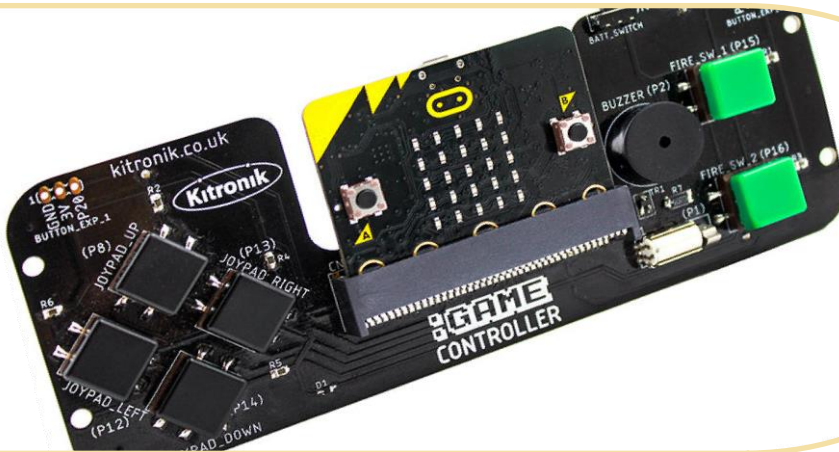
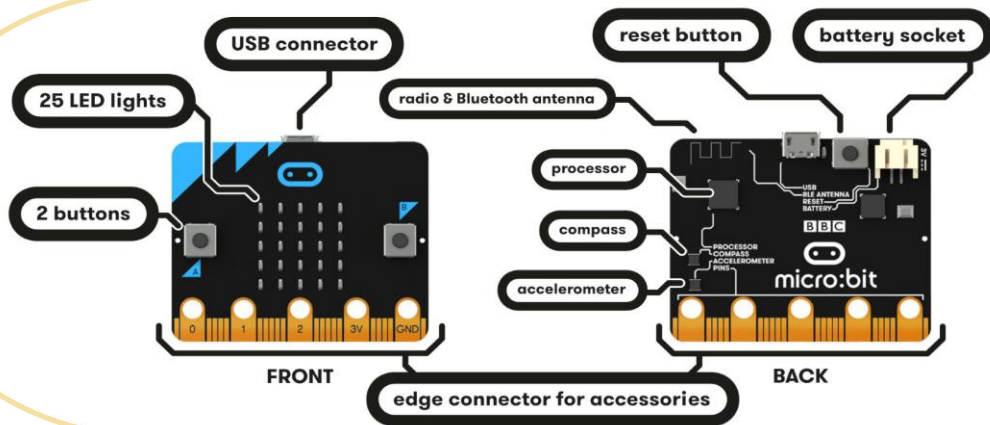

## PROGRAMMING THE **MICRO:BIT**

Pupils in S2 and S3 really enjoyed programming our micro:bit devices - they always do. It's a firm staff favourite too!

The micro:bit is a pocket-sized computer that introduces you to how software and hardware work together. It has an LED display, buttons, sensors and many input/output features that, when programmed, let it interact with you and your world.

Pupils in S3 even got to program the devices to operate buggies and remote controllers to drive traffic all over the school! Beep! Beep!



It has been another exciting and successful year in the Maths department. More pupils than ever participated in the United Kingdom Maths Trust Junior Mathematical Challenge where pupils across the UK participate and answer a range of problems that encourages **mathematical reasoning**, **precision of thought**, and **fluency** in using basic mathematical techniques.



The challenge is far from easy, and all the pupils and their families should be very proud of themselves. This year 28 awards were achieved by our pupils.

A special congratulations to Ciaran Jones in S1 for achieving the best in the year for S1s and to Emmanuel Okungbowa for the same in the S2s. Emmanuel has also qualified for the next round of the challenge which is a huge achievement. Congratulations to all.

The fun does not stop with the S1-S3s in the classroom. Here you can see Mrs Doyle's Higher Maths class taking part in a zombie escape room!

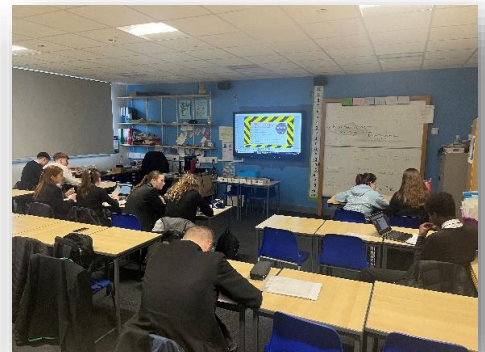

Congratulations to our hand-picked Enterprising Maths Team, Lucy, Zach, Lucas and Ebony who travelled to Gryffe High School to compete against local high schools in a series of fiendish maths challenges. You did yourselves and the school very proud.



It has been another fantastic year for the pupils and staff in the Maths Department and we look forward to doing it all again next year!

## Christmas Concert

Our annual Christmas Concert was a huge success again this year. The pupils who participated worked so hard to prepare for the event. We were entertained by Jamie on the xylophone, Harry on the guitar, Christopher-Luke on the drums and the St B's Ensemble to mention just a few. We are so proud of them all!



## S1 Jazz Workshops

A group of S1 pupils were lucky enough to be involved in a series of Jazz workshops with two professional musicians. Konrad and Alan came into class for six weeks and demonstrated the art and skill of improvising. The class learned to play and improvise on lots of different styles of music including, jazz, blues and Latin American.



## London Trip 2025

It's that time of year again where the Music Department are busy preparing to organise another trip to London. We have a group of S2 and S3 who have already signed up and more details and an information evening will follow shortly. If any pupils in these year groups are still interested and haven't had the chance to sign up yet there might be a few places still available so, please come forward and let Miss Gillespie in the Music Department know ASAP.

The trip will be taking place on Tuesday 20<sup>th</sup> May – Thursday 22<sup>nd</sup> May 2025. We will travel by train to London Euston, stay for two nights at the Royal National Hotel, take in two West End shows, participate in a stage combat workshop with a professional stunt actor at Pineapple Dance Studios, have a backstage tour of the Royal Opera House and take in lots of iconic London sights like Westminster and Big Ben, Trafalgar Square and Buckingham Palace.

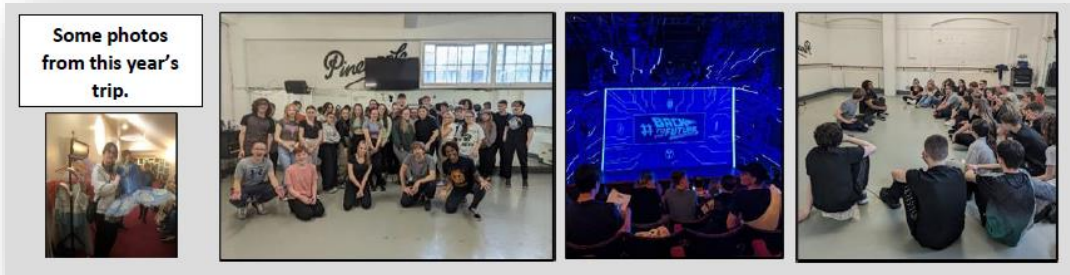

## Renfrewshire Young Musician of the Year

Our very talented S3 pupil Mariya represented the school at the Renfrewshire Young Musician of the Year. She performed Solveig's Song by Edvard Greig.

Well done, Mariya!



## Retirement

After a long career, this session we have said goodbye and good luck to Mr Bolam our Instrumental Guitar teacher. He has been an important member of the department and played a huge part of developing the skills of our young people. Staff and pupils are going to miss him as he now takes time to enjoy his retirement.



If you haven't already, you can follow the Music Department on X (Twitter) [@stbensmusic](https://twitter.com/stbensmusic). Here you will find information about what pupils are doing in class.



2023 finished with the Christmas Disco for S1-3 pupils organised by Miss McMillan and Miss Shearer, and the Christmas Ceilidh organised by Mr Millar on the last day of term.

Pupils at both events had a ball and were in festive spirits!



Miss Shearer's Sports Development class planned and led the school cross country championship for S1-3 pupils. The event was well organised by our senior pupils, and runners displayed excellent resilience and mental toughness in adverse weather conditions. Top performing pupils went on to compete in the Renfrewshire cross country event (pictured bottom right).





Miss McMillan's dancers competed at the Renfrewshire School's competition and produced fantastic displays winning:

Senior Team- 1st 🏆

Junior Team- 1st 🏆

Senior Duet- 1st 🏆

Junior Duet- 3rd 🏆

Senior Solo- 1st 🏆

Junior Solo- 1st 🏆



In March, Lynsey Dawson (Active Schools) took senior pupils Kiera, Sophie and Saoirse to the West Para Sport event 2024.

They had a great day supporting clubs, schools and NGBs.



St Benedict's junior volleyball, basketball and girls' football teams competed at the OneRen Secondary Games in April. Mr Millar's volleyball team came 2<sup>nd</sup> and Mr McGeady's basketball team came 3<sup>rd</sup>!



In May, the PE Department hosted the School Athletics Championship for S1-3 pupils, rounding off the athletics block. The weather was excellent, and pupils enjoyed the day.



### Sports Day Winners

- S1** Charlotte Corey  
Ryan Haig
- S2** Emmanuelle Okungbowa  
Caitlin Moore
- S3** Alanna Cuthill  
Josh O'Neil

Clubs and teams ran regularly throughout the year at lunchtimes and after school with teams competing in various local competitions. These included Miss Shearer's netball and senior football teams, Miss Shearer and Miss McMillan's dance, gymnastics and trampolining clubs, Mr Millar's volleyball team, Mr McGeady's basketball team, Mr Scarff's S2/3 football team, with Miss Delaney as the football representative, and Mr Taylor's S1 football club.

Thanks very much to all the staff involved in taking clubs and teams to create opportunities for pupils!



# Religious Education

It's been a busy few months in the R.E. Department!

We've been continuing our faith and learning journey through participating in classroom activities in other moments of faith witness throughout the school.

Below are some of the highlights!



## Leadership Award

Well done to Mrs Macdonald's S6 Leadership Award class for a bumper year of activities, including the fantastic Valentine's Dance for our S1 and S2 pupils!

A very special thanks too goes to all the staff who supported the group and helped with all their various activities over the year.

## Walk for SCIAF

Well done and thank you to all our young people and staff who walked for SCIAF over Lent. A beautiful act of charity and Lenten observance!

If you would like to support the work of SCIAF you can donate [here](#).



## Twitter (X)

You can follow us on [Twitter \(X\)](#) to keep up to date with all that is going on in St. Benedict's Religious Education Department.



Well done to all of our Caritas candidates who were successful in their undertaking of faith witness in the service of others over the past year.

Pictured are two of our Caritas students, Michaella and Ava, who joined with Ms MacNeil and Brittany from St. Vincent's Hospice to take part in a bucket collection at Tesco, Linwood. Amazing work!

The Caritas Award was founded just over a decade ago following Pope Benedict's visit to Scotland. The award asks young people to use their faith as a starting point for reflection leading to activities which show their faith in action.



Our S6 pupils commit to forty hours' work throughout the year in their school community and parishes. This allows them to give something back to society helping others who need our support.

The Award Programme is unique to Scotland, and we are very proud of our young people who embarked on the Caritas journey this year.

They came to know and value the act of charity and there is no doubt that they will carry this forward in their own lives as they leave the community of St. Benedict's.



The Award Ceremony was in Glasgow on the 3rd June 2024 and celebrated our S6 pupils receiving their Caritas medals and certificates.

The BGE Science classes have been actively engaged in their science journey this year.

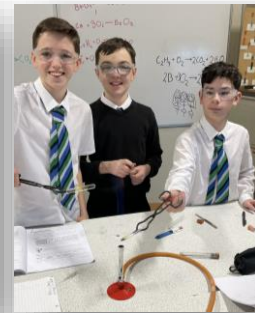
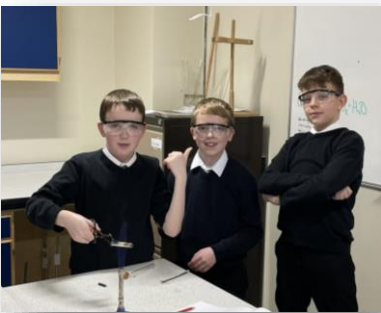
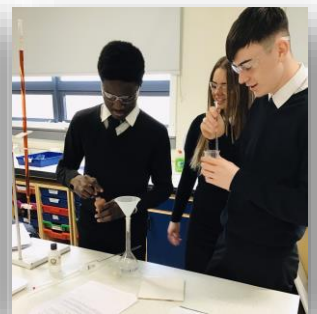
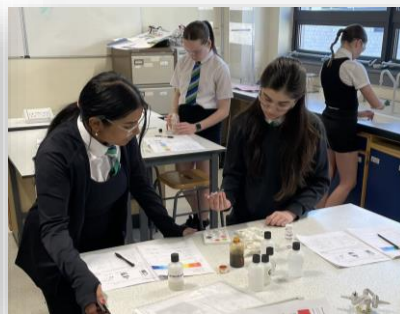
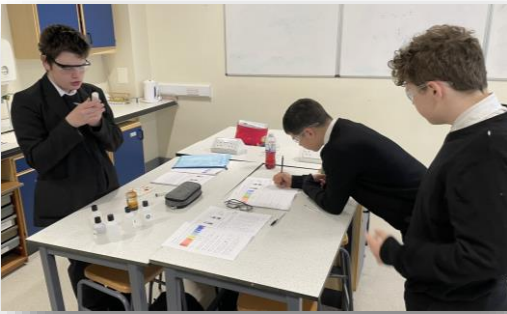
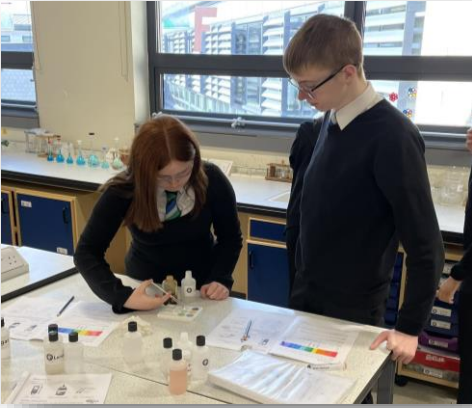

Mr. McPhee's S4 pupils completed their excellent climate change projects this year. The pupils presented these to their peers to highlight the importance of tackling climate change.

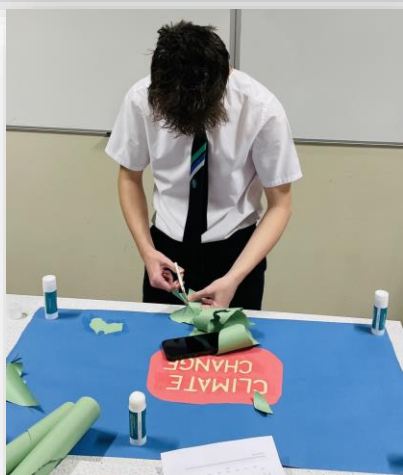

## Chemistry Escape Rooms

Chemistry pupils this year have taken part in chemistry escape rooms where they were against the clock and each other to answer SQA questions to escape!

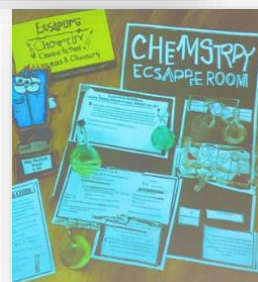

In Social Subjects we strive for excellence in our learning and teaching. Staff have been working hard to showcase the quality work our pupils have been creating - follow us on [@socsbstbens](https://www.instagram.com/socsubsstbens).

This session we have been proud to support our pupils through our core social subjects Geography, Modern Studies and History. In the Senior Phase we also offer Skills for Work Travel and Tourism and Higher Politics.

## Dynamic Earth

Miss Urquhart led the S2 Dynamic Earth trip in February. Dynamic Earth is a science centre and planetarium where our pupils experienced exhibitions including Restless Earth, Polar Extremes and Tropical Rainforest. A great day was had by all!

[@ourdynamicearth](https://www.instagram.com/ourdynamicearth)

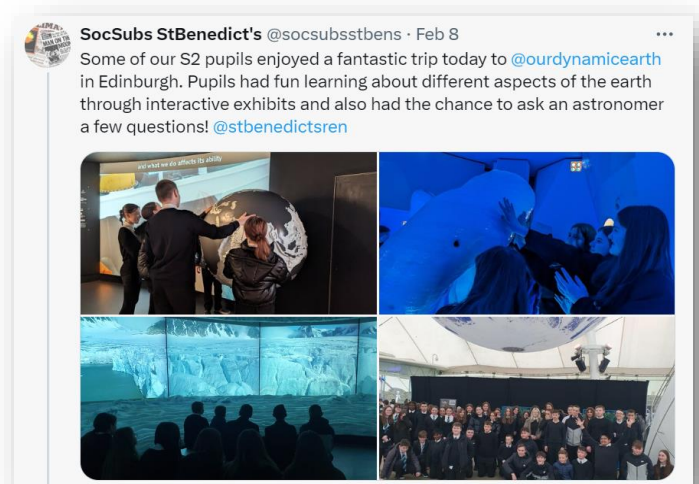

## Vision Schools Scotland

The Social Subjects Faculty was recognised by Vision Schools Scotland for our commitment to Holocaust education in 2023. We are honoured to continue supporting Holocaust education in session 2024-25.

[@VisionSchools](https://www.instagram.com/VisionSchools)

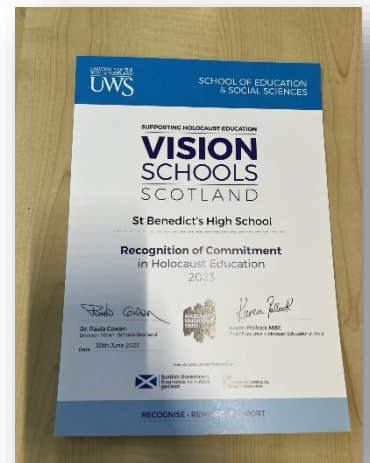

## Loch Lomond And The Trossachs National Park

Following on from our very successful trip to the Loch Lomond in November 2023, the National Park Rangers will be in school in June to discuss land use and conflict. The presentation will be for the S3 Geographers and will greatly help them in their preparations for exam season 2024-25.

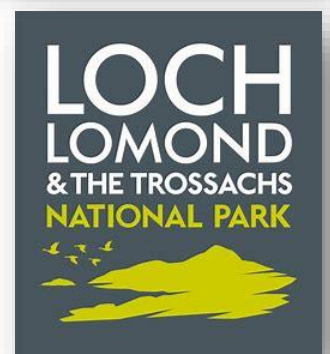

## MSP Visit

Tom Arthur MSP met with some of our eager Modern Studies pupils. Pupils asked Mr Arthur many questions concerning his work as an MSP, with one of our pupils wanting to know specifics of how to become an MSP. Mrs O'Neill was thrilled with how engaged our pupils were! Many more exciting opportunities are ahead for our new Modern Studies candidates.



## Exciting News!

We are pleased to announce two exciting trips being arranged by staff.

Mrs O'Neill is organising a trip to New York and Washington DC in October 2025. The letters have been issued and we have had an overwhelming response. Mrs O'Neill would like to thank all pupils and parents for the support!



Miss Urquhart is organising a trip to Switzerland for June 2026 with Diverse School Travel. The itinerary includes a 2000m high cable car, a train journey through caverns and a boat on an underground lake! We will also visit Zermatt to view the Matterhorn. We hope to announce the lucky group by August 2024 so get your form in now.







# Technical Department

**PUPILS IN THE TECHNICAL DEPARTMENT THIS TERM HAVE BEEN DEVELOPING SKILLS IN THE FOLLOWING AREAS. EXCITING TIMES AHEAD FOR OUR THE LAUNCH OF OUR NEW SUBJECT JEWELLERY DESIGN !**

## GRAPHIC COMMUNICATION

The course introduces learners to the diverse and ever-increasing variety and complexity of presentation methods employed in graphic communication/design. Pupils will learn industry standard Computer Aided Design skills (CAD) using Autodesk Inventor. Digital and creative skills gained are of particular benefit to those aiming for careers in architecture, engineering, surveying and design.

## SILVERSMITHING & JEWELLERY DESIGN

This creative course introduces pupils to the workings of the Silversmithing & Jewellery workshop. Pupils gain expertise in the skills of design transfer, marking out and piercing. Design and creative skills gained are of particular benefit to those aiming for careers in Model making, Blacksmith, Animator, Orthodontist, Dentist Graphic Designer, Medical Illustrator, Electrician, Plumber or Set Designer.

## PRACTICAL WOODWORKING SKILLS

The Course is largely workshop-based, combining elements of theory and practical woodworking techniques. Pupils will further develop skills in safe working practices and become proactive in matters of health and safety. They learn how to use a range of industrial standard tools and machinery, equipment and materials safely and correctly. Some career paths include joinery, construction, project management, timber production, set & exhibition building, furniture design and cabinet making.



**TECH**

**OPTION 1**



SCAN ME

**OPTION 2**



SCAN ME

**OPTION 3**



SCAN ME

**New course for 2024**

Learn more at:

 @STBENEDICTTECH

 @STBENEDICTTECH

 ST BENEDICTS TECH

 [http://](http://ORAETLABORA.CO.UK) ORAETLABORA.CO.UK



# Technical Department

## S2 Model

### Tealight holder



Learn more at:

 @STBENEDICTTECH

 @STBENEDICTTECH

 ST BENEDICTS TECH

 <http://ORAETLABORA.CO.UK>



# Attendance and Timekeeping

We have been working hard to ensure that young people in St. Benedict's High School continue to achieve and attain to their highest level. Regular attendance and punctuality at school are essential for this. Your support here as a parent/carer is crucial.

Please ensure that your child is only absent from school if they are genuinely unwell or there is a valid reason. Absences must be reported to the school office by 8.45am. If young people are absent on a regular basis or if they are late to class, this is detrimental to their education and learning. Please be aware that if your child's attendance or timekeeping falls below the standards we expect, we have a duty of care to inform you and to follow Renfrewshire Council procedures.

## Pupil Reports and Target Setting

Monitoring and tracking of your child's progress helps us to ensure your child can achieve their potential and is therefore a very important part of his/her education.

As part of our monitoring and tracking system, your child will be involved in regular discussions with staff to identify strengths, areas for development and next steps. Please also discuss these reports with your child.

Over the course of a full session, you will receive the following communication.

The school calendar on the website highlights the dates these are issued.

1. A full written report detailing your child's strengths and areas for development within each subject of study.
2. Tracking reports detailing levels of achievement and ratings for effort, behaviour and homework.
3. A parent-teacher meeting with an opportunity for a verbal report.

If you have any issues you wish to discuss further, please contact your child's pastoral care teacher or year group Depute Head Teacher.

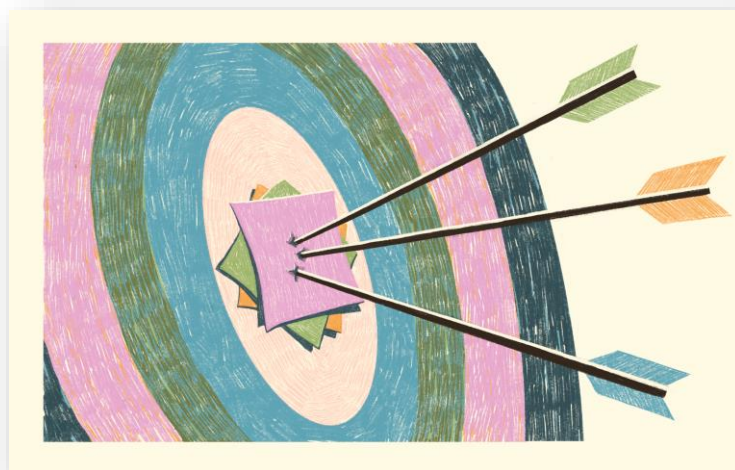



# *We are a nut-free school!*

We are a nut-free school as some members of our school community have a **life-threatening allergy to nuts**.

Nuts and products containing nuts e.g. Nutella, Snickers Bars etc. should not be brought into school.

It is essential that these members of our school community are not in contact with anyone who has eaten nuts that day as this can also trigger a reaction.

To ensure the safety of all members of our school community, it is imperative that this ban on nuts and nut-containing products is adhered to.

Thank you for your continued support in this matter.





# St. Benedict's Website and Twitter

I draw your attention to our school's website <http://www.oraetlabora.co.uk> as an interesting and ongoing source of valuable information on events and achievements at the school, including our calendar for this session.

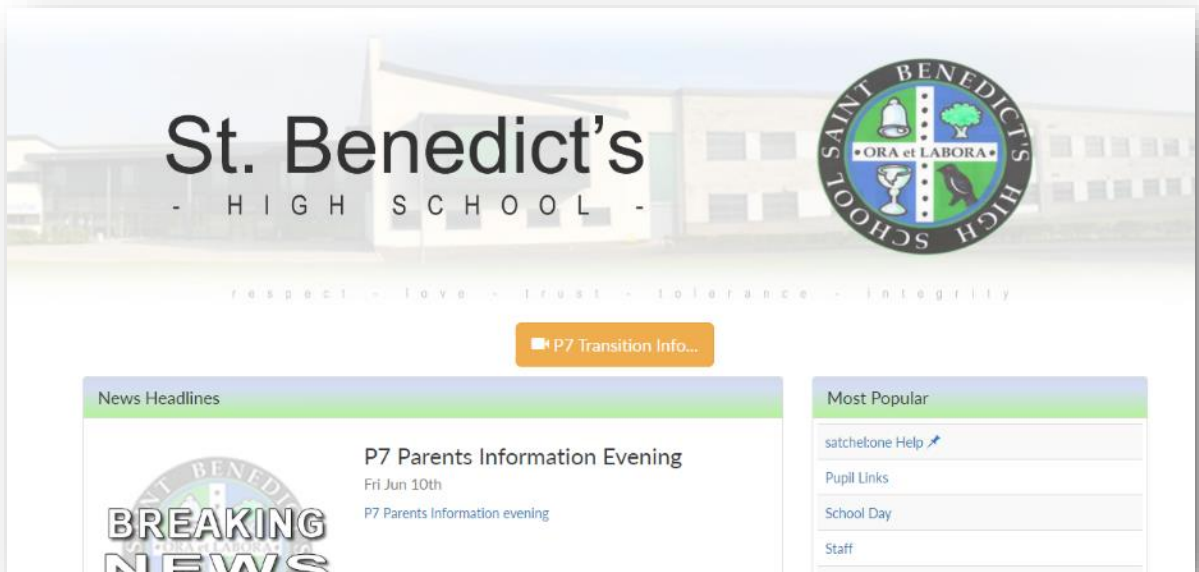

Our Twitter feed is a great source of information about the school. We now have over 2,000 followers - you can follow us on [@stbenedictsren](https://twitter.com/stbenedictsren)





# Dates for your diary:

Event	Status	Date
In-service day	School open for teachers and staff only	Wednesday 14 August 2024
In-service day	School open for teachers and staff only	Thursday 15 August 2024
Start of term	Pupils' first day at school	Friday 16 August 2024
Local holidays	Schools closed	Friday 27 September 2024
Local holidays	Schools closed	Monday 30 September 2024
Normal school day	Schools open	Tuesday 1 October 2024
In-service day	School open for teachers and staff only	Friday 11 October 2024
Mid-term holidays	Schools closed	Monday 14 October 2024
Mid-term holidays	Schools closed	Tuesday 15 October 2024
Mid-term holidays	Schools closed	Wednesday 16 October 2024
Mid-term holidays	Schools closed	Thursday 17 October 2024
Mid-term holidays	Schools closed	Friday 18 October 2024
Second half of term	Schools open	Monday 21 October 2024
St. Andrew's Day	Schools closed	Monday 2 December 2024
Normal school day	Schools open	Tuesday 3 December 2024
Christmas Holidays	Schools closed	Monday 23 December 2024
Christmas Holidays	Schools closed	Tuesday 24 December 2024
Christmas Holidays	Schools closed	Wednesday 25 December 2024
Christmas Holidays	Schools closed	Thursday 26 December 2024
Christmas Holidays	Schools closed	Friday 27 December 2024
Christmas Holidays	Schools closed	Monday 30 December 2025
Christmas Holidays	Schools closed	Tuesday 31 December 2025
Christmas Holidays	Schools closed	Wednesday 1 January 2025
Christmas Holidays	Schools closed	Thursday 2 January 2025
Christmas Holidays	Schools closed	Friday 3 January 2025
Start of term	Schools open	Monday 6 January 2025

Further term and holiday dates can be found [here](#).



# Feedback

We welcome any feedback on the content of the Summer Newsletter or indeed any other aspect of the work of the School. If you wish to make an electronic reply, please do so through the school email address:

[stbenedictshighenquiries@renfrewshire.gov.uk](mailto:stbenedictshighenquiries@renfrewshire.gov.uk)

Pupil's name:

Year group:

Comment:

Signature of parent/carer:

Name of parent/carer (please print):